

STOREFRONT SYSTEMS

The optimal choice for projects of all storefront sizes

Columbia Commercial Building Products (CCBP) manufactures storefront systems designed for flexibility and built with quality and performance in mind. This extensive line of flush-glazed storefront systems is built to meet your design requirements. Systems are offered in a variety of depths and accept 1/4" or 1" glass. Identical EPDM gaskets are utilized on the interior and exterior of systems.

FEATURES & BENEFITS:

- 1-3/4" x 4-1/2" System for 1/4" glass
- 2" x 4-1/2" System for 1" glass
- 2" x 4-1/2" Thermally Improved System
- Screw-spline assembly
- EPDM gasketing
- Installation manuals
- Door framing components available
- Class II clear anodized material
- Class II bronze anodized material

PERFORMANCE DATA:

- Air performance per ASTM E283
 - Water performance per AAMA 501 and ASTM E331
 - Structural performance per ASTM E330
- * Tests conducted by independent laboratories.
Full report is available upon request.*



Visit ccbpwin.com/architectural-aluminum to learn more.

sales@ccbpwin.com | 800.668.1645

1 3/4" x 4 1/2"

Flush-Glazed System for 1/4" Glass

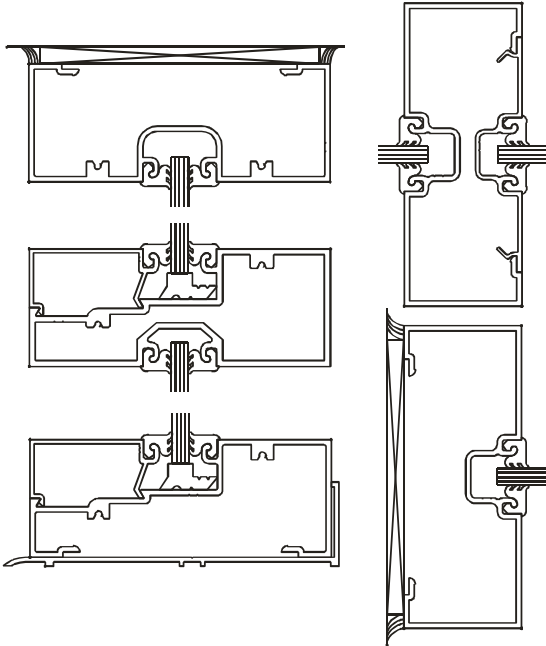

2" x 4 1/2"

Flush-Glazed System for 1" Glass

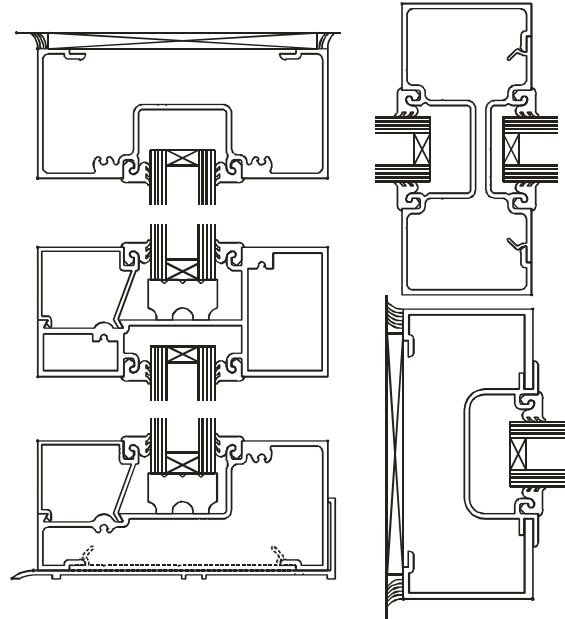

2 x 4 1/2"

Thermal Flush-Glazed System for 1" Glass

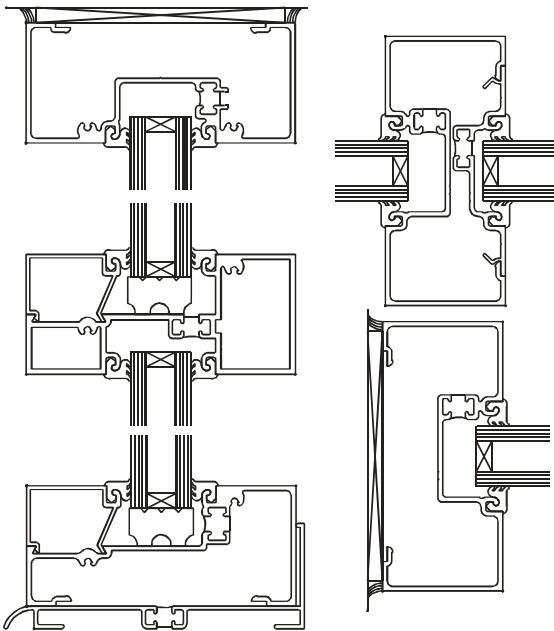

Columbia Commercial Building Products

4361 Firestone Blvd. South Gate CA 90280

Call your local sales representative for more information.

Email: sales@ccbwin.com | Phone: 800.668.1645 | Fax: 972.722.6033

FHC | **ALUMINUM**
STOREFRONTS & ENTRANCE SYSTEMS

CCBP COLUMBIA
COMMERCIAL BUILDING PRODUCTS
A DIVISION OF FRAMELESS HARDWARE COMPANY LLC